

May 2023

**FYUGP STRUCTURE UNDER NEP  
GAUHATI UNIVERSITY**

**NEP 2020**

**INFORMATION BOOKLET**  
**Four-year Undergraduate Programme**



**NEP Implementation Cell**

Email : [iqac@gauhati.ac.in](mailto:iqac@gauhati.ac.in)  
Gauhati University, Guwahati, Assam 781014, India



Gauhati University

# Information Booklet (2.0)

On Four-Year Undergraduate Programme (FYUGP)  
of Gauhati University

**NEP Implementation Cell**  
IQAC, Gauhati University

May, 2023

## Contact

**NEP Implementation Cell**  
IQAC, Gauhati University  
Contact: [iqac@gauhati.ac.in](mailto:iqac@gauhati.ac.in)



Version 2.0. © Gauhati University. All rights reserved. Unauthorised copying and distribution are prohibited.

# Table of Contents

<b>1 Introduction</b>	<b>8</b>
1.1 Salient features .....	8
1.2 Progression .....	9
1.3 How different are the courses? .....	9
<b>2 FYUGP degrees &amp; course structures</b>	<b>12</b>
2.1 Multiple exits & entries .....	12
2.2 Core courses .....	13
2.2.1 Major and Minors .....	13
2.3 Common courses .....	13
2.4 The fourth year .....	14
<b>3 Details of Curriculum – Degree in a Stream</b>	<b>16</b>
3.1 Degree with Major and Minors .....	16
3.1.1 Legends .....	16
3.1.2 Core Course description .....	17
3.2 Degree with only Minors .....	17
3.2.1 Core Course description .....	17
<b>4 Examples</b>	<b>18</b>
4.1 Example #1 – Degree with Major and Minors .....	18
4.2 Example #2 – Degree without Major .....	19
<b>5 Subject Details – Core Subjects</b>	<b>21</b>

## TABLE OF CONTENTS

---

5.1 Subject groups .....	22
5.1.1 Key points .....	22
5.2 Prerequisites, Requirements, & Constraints.....	22
5.3 Subject Group — Arts .....	23
5.4 title .....	23
5.5 Subject Group — Science .....	24
5.6 Major subjects.....	24
5.7 Minor Subjects .....	25
<b>6 Multidisciplinary &amp; Skill Courses</b>	<b>27</b>
6.1 Multidisciplinary subjects.....	27
6.2 Skill Courses .....	27
<b>7 List of prerequisites &amp; requirements</b>	<b>29</b>
7.1 Arts.....	29
7.2 Interdisciplinary.....	30
7.3 Science .....	31
7.4 Commerce & Management.....	32
<b>8 Bachelor’s Degree in Commerce</b>	<b>33</b>
8.1 Common Courses.....	33
8.2 Major : Accountancy .....	34
8.3 Major : Finance.....	35
8.4 Major : Human Resource Management .....	36
8.5 Major : Marketing Management .....	37
<b>9 Degree in a Discipline</b>	<b>39</b>
9.1 Salient features .....	39
9.2 List of disciplines & degrees.....	39
9.2.1 Vocational Disciplines .....	39



# 1 | Introduction

The Four-Year Undergraduate Programme (FYUGP) of Gauhati University is as per UGC's Curricular Framework, published in November 2022. The course structure of FYUGP is built on the Choice-Based Credit System (CBCS). Though, the FYUGP is basically a CBCS, it is radically different from the courses running under CBCS. Namely, it does not differentiate between so-called *Honours* and *Pass* courses existing under CBCS. Basically, the FYUGP is based on the system of education under *Liberal Arts*.

## 1.1 | Salient features

Structure-wise, the present Bachelor's Degree programme under the CBCS is a 3-year degree programme at the end of which, a student will be awarded a Bachelor's Degree in Arts, Science, or Commerce. One can also have a Bachelor's of Vocation degree, being run in some colleges, which in short form known as the BVoc degree. The two systems – Bachelor's Course under CBCS and Bachelor's Course under the FYUGP of NEP are different in the following ways.

- **Duration**

While under CBCS, one has a 3-year degree programme, under the NEP's FYUGP, it is a 4-year degree programme.

- **Exits & Entries**

Under CBCS, one needs to complete the full 3-year programme in order to get a degree. There is no provision for dropping out of the programme in the middle. While in the FYUGP, one has choice to exit from the programme thrice – after one year, after two years, and after three years. If one exits the programme after one year, one gets a certificate. If one exits after two years, one gets a diploma. If one exits after three years, one gets a Bachelor's Degree. And finally if a student completes the whole 4-year, one gets a Bachelor's Degree (Honours).

### Key Points

*If you exit in the middle, the doors are still open for you to enter into the programme again and you can start the journey from where you left. No such provisions exists in the CBCS.*

- **Honours and Major**

Under the CBCS, we either have Bachelor's Degree (Honours) or a regular Bachelor's Degree. In FYUGP, we get a Bachelor's Degree with Major after 3 years and a degree



with Major & Honours after 4 year.

- **Progression**

If a student exits the FYUGP after 3 years, s/he will need to take admission into the first year of a Master’s programme, which is a 2-year degree programme. However, if a student fully completes an FYUGP, s/he needs to take admission into the second year of a Master’s programme and needs to complete only one year to get a Master’s Degree. Under CBCS, there was no such pathways.

- **Progression to Doctoral Studies**

Once a student takes admission into a Master’s programme either after 3 years of the Bachelor’s programme or after FYUGP, one will be able to take admission into a Doctoral programme leading to the Degree of PhD. However, if a student is exceptionally good, one can directly take admission into a Doctoral programme right after the FYUGP, bypassing the Master’s programme.

## 1.2 | Progression

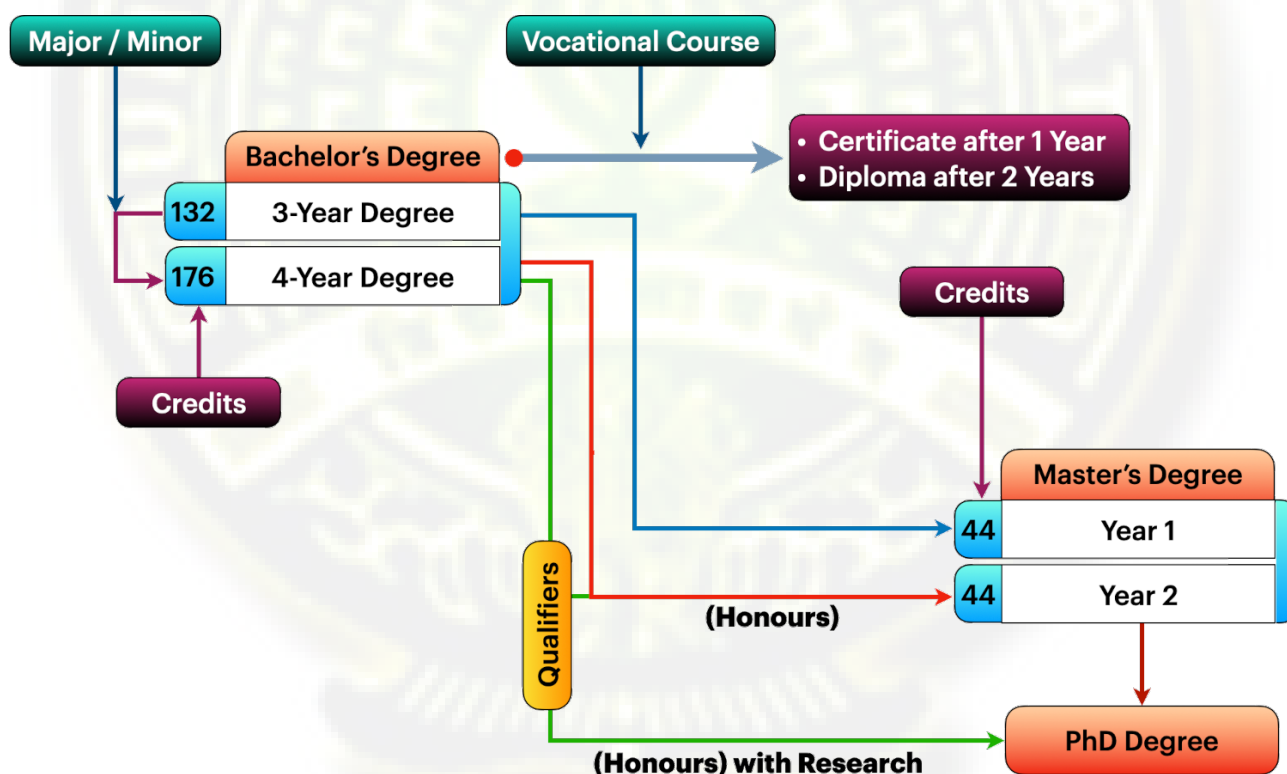

Figure 1.1: Progression under GU-FYUGP

## 1.3 | How different are the courses?

The major differentiator between the FYUGP and the existing CBCS is the student’s ability to study different subjects of choice and also the ability to switch between subjects. Basically, there are two parts of a course under the FYUGP – (a) Core Courses and (b) Common

Courses. As the name suggests, different students study different core courses and all students study the common courses. Below, we describe what you will study in different parts of the programme.

- **First Year (Semester I & II)**

In the first year, one studies three different core subjects – one paper of each subjects per semester. Besides, one needs to study a host of common subjects that we have designed as per UGC’s Curricular Framework. Details of these courses are described in this booklet.

- **Second Year (Semester III & IV)**

- **Semester III**

In the third semester, one will usually continue with the same core subjects that have already been chosen in the first year and again study some common subjects. In the third semester, one will also take a step forward to study the favourite subject by **declaring** one of the core subjects as a **Major** subject and other two as **Minors**. However, the structure of the programme remains same as in first & second semesters.

- **Semester IV**

From Semester IV onwards, one will primarily study the Major subject by taking at least four papers, some of which may be elective depending on the subject concerned.

As the programme structure in the third semester is same as the first & second semesters, one will have the option of changing the Major in fourth semester to any one of the other two Minors as well, even if one has already declared a Major in the third semester. However this has the condition that the new Major subject of choice has vacancy.

- **Third Year**

In the third year, one will continue to study the Major subject to complete a full set of 15 papers in Majors.

- **Fourth Year**

If one intends to progress to the fourth year, s/he will be devoting the time in studying advanced courses which will be at the level of initial Master’s degree papers. Besides, one will also have the opportunity of engaging into research work with the faculty members.

Besides the above, there are some more unique features of the FYUGP. They are

- **Open Core Credits**

From fourth to sixth semester, one will have time for 4 optional open core credits per

### Key Points

*If you would like to change a Minor subjects in the third semester, you can change with the following limitations:*

- 1. You will be able to change a subject, provided the new subject can accommodate you. This can be a problem with science subjects as they need to ensure laboratory space for each student.*
- 2. Besides, as you have already abandoned the first year time studying a subject which you no longer want to continue,*

### Key Points contd.

*you will need to use your open core credits to compensate for the new subject. This will be more clear once you see the examples we have given afterwards.*

semester, which one can utilise to study either of the Major or two Minors. They can also come handy, if one had changed a Minor subject in between.

- **Double Major**

If a student is ready to do some more hard work, s/he can take some extra online courses (from designated sources only) related to the Minors and can then convert one of the Minors to a second Major by the time one completes 3 / 4 years of study. This is over and above the first Major. In this case, one will have a Bachelor's Degree with Double Major.

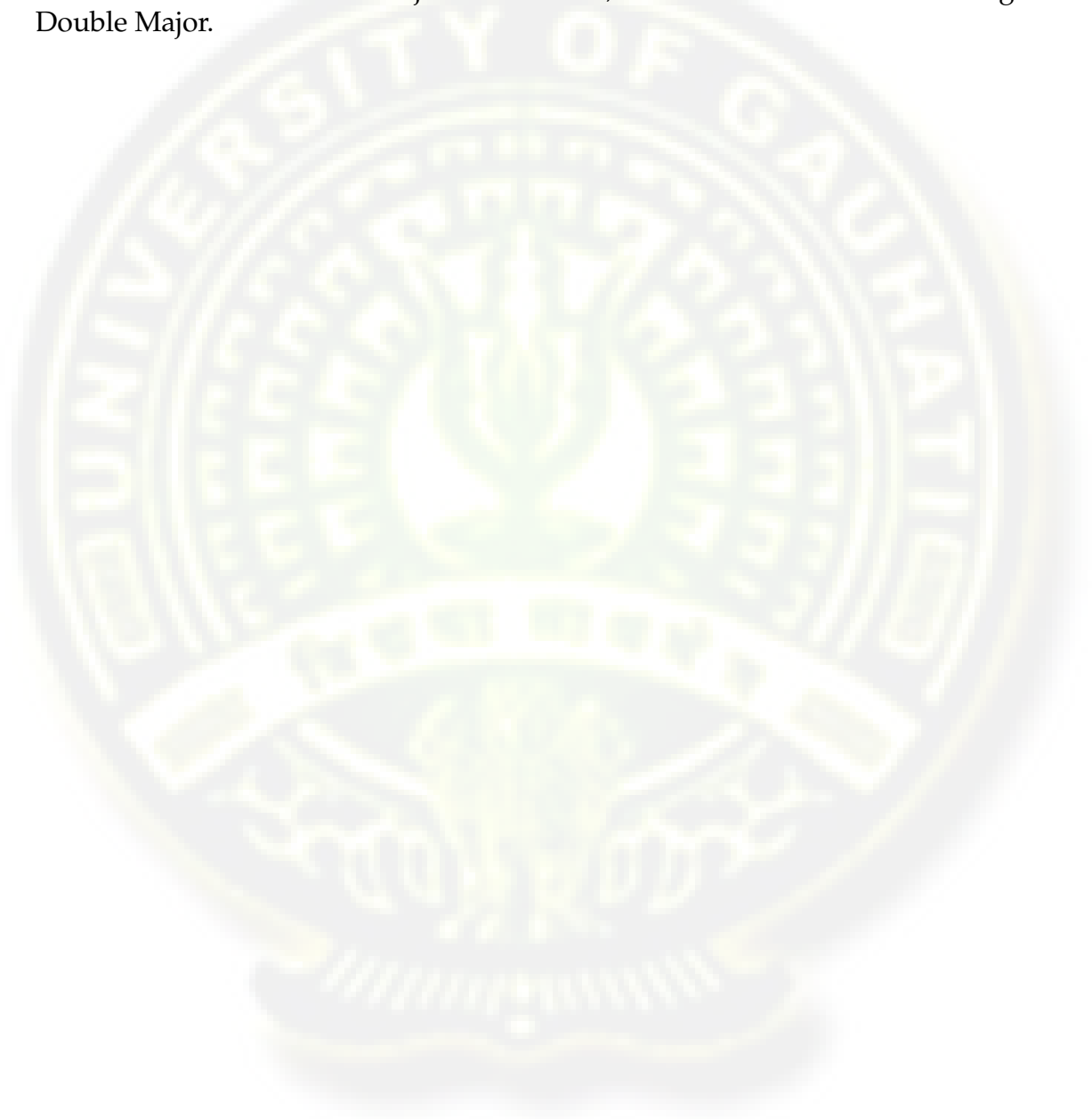

## 2 | FYUGP degrees & course structures

The FYUGP at GU is designed to offer two types of Bachelor's Degrees to the students at the end of the successful completion of the programme — (i) Bachelor's Degree in a Stream and (ii) Bachelor's Degree in a Discipline. The word **stream** here refers to Arts, Science, Commerce, and Management. In case of a degree in a stream, the student studies a multitude of different subjects, usually mixing different disciplines, which leads to a truly multidisciplinary degree. While in case of a degree in a discipline, the student is confined to a certain sets of disciplines. However, in both cases, the student studies equal number of courses (i.e. papers) — so there is no weightage of any kind to either of the two types of degrees.

For both the types of degree programmes, course-wise, the whole FYUGP is divided into two parts — (i) Core Courses and (ii) Common Courses. The minimum credit allocation for a 3-year programme is 84 credits in Core Courses and 36 credits in Common Courses, which comes to a total of minimum 120 credits for a 3-year programme. With the fourth year, the minimum credit requirements becomes 160. A student can however earn up to a maximum of 132 credits in a 3-year programme and 176 by the fourth year.

### 2.1 | Multiple exits & entries

As mentioned before, a student can exit after any year during the FYUGP. Depending on the exit level, a student can get a certificate, diploma, or a degree.

If a student exits after one year into the programme, s/he will be eligible to get a certificate, if she clears all the courses at that point of time. Similarly, s/he will be getting a diploma if s/he exist after two years into the programme, after clearing all the courses up to that point of time. Eventually, after three years, s/he will get a Bachelor's Degree.

#### Exit Courses

*Every students who wants to exit before 3 years into the programme, **MUST** complete an additional Vocational Course of 4 credits.*

It should however be **noted** that if a student exits the FYUGP at the third year with a Bachelor's Degree, s/he will not be able to seek a reentry afterwards into the fourth year. Rather s/he will need to take admission into the first year of a Master's programme.

Every student who is in the third year of the FYUGP, can advance to the fourth year. After successful completion of the fourth year, s/he gets either a Bachelor's Degree (Honours) or a Bachelor's Degree (Honours) with Research.

## 2.2 | Core courses

The Core Courses determine the ultimate degree, diploma, or certificate a student will earn at the end of third (or fourth) year, second year, or first year, respectively. The performance in the Core Courses will also determine the grade of the student in the final examinations. Total minimum credit requirement is 84 for the Core Courses, which translates to 21 courses (i.e. papers) with a credit allocation of 4 per course (paper). A student will need to study at least three Core subjects.

The Core Courses have to be chosen among a plethora of subjects offered (see the section on Subject Details) for both the types of degrees, respectively. In case of a Bachelor's Degree in a Stream, the components of the Core Courses are Major and / or Minors, while in case of a Bachelor's Degree in a Discipline, there are no Majors and Minors.

### 2.2.1 Major and Minors

In case of a Bachelor's Degree in a Stream, a student either chooses a Major and Minors or just Minors from among the subjects. In any case, a student needs to complete 21 courses or 84 credits by the third year. Please see the examples that we have given in this booklet. A Major course **MUST** carry a minimum credit of 60 and a Minor course should carry a minimum credit of 12.

Usually, for majority of the students, the Core Course will consist of one Major and two Minors.

## 2.3 | Common courses

The common courses are to be studied by all students alike and all-together they carry a total credits of 36 over a 3-year period. These courses are further divided into five (5) sub-categories, as described below.

- **Multi-disciplinary Courses**

These are 3-credit courses spanning over five different groups of subjects — (i) Natural and Physics Science, (ii) Mathematics, Statistics, and Computer Applications, (iii) Library, Information, and Media Sciences, (iv) Commerce and Management, and (v) Humanities and Social Sciences. The level of these courses are of Class XII.

Each student need to take at any three papers, each with 3-credits from these five sub-groups during Semesters 1-3.

#### **Key Points**

*A student CANNOT choose a multidisciplinary subject, if s/he has already studied that subject during Class XI-XII.*

*Also the subject of these courses MUST not be among the Core Subjects the student has already chosen.*

- **Ability Enhancement Courses (AEC)**

This is an 8-credit course covering Modern Indian Languages (MIL) and English Usage (Communication).

Each student needs to complete two papers of 4-credits each – one from English Usage and other from the group of MIL, especially designed for this purpose. Both these courses are further divided into two 2-credit courses each. The English Communication course is to be completed during Semesters 1-2 and the MIL course is to be completed during Semesters 5-6.

- **Skill Enhancement Courses (SEC)** These are various skill courses with total credit allocation of 9. All students need to complete three skill courses, each with 3 credits during Semesters 1-3.

- **Value Added Courses (VAC)**

The VAC courses will come from four sub groups — (i) Understanding India, (ii) Environmental Science, (iii) Digital and Technological Solutions, and (iv) Health & Wellness, Yoga Education, Sports, and Fitness. All together they will have a credit allocation of 6.

Each student will have to take any three courses, each of 2-credit, from any three groups during Semesters 1, 2, & 4. Here one course from the Environmental Science group is *compulsory* except if the student takes a core course on Environmental Science.

- **Internship**

All student are to carry out an Internship with a credit allocation of 4. The internship can be carried out in any semester during Semesters 3-6. As internships are meant to be done during semester breaks, they will *not* interfere with other classes.

## 2.4 | The fourth year

In the FYUGP, the fourth year is at par with the first year of a Master's programme, as a student can directly can take admission into the second year of a Master's programme after the successful completion of the FYUGP.

In the fourth year, a student has to complete one compulsory paper on Research Methodology (REM) in the Semester VII, which is a 4-credit theory paper. The rest of courses will consist of Advanced Core Courses and a Dissertation. The detailed structure for the fourth year will be published soon.



# 3 | Details of Curriculum

## Degree in a Stream

The complete curricula for GU-FYUGP are as follows.

### 3.1 | Degree with Major and Minors

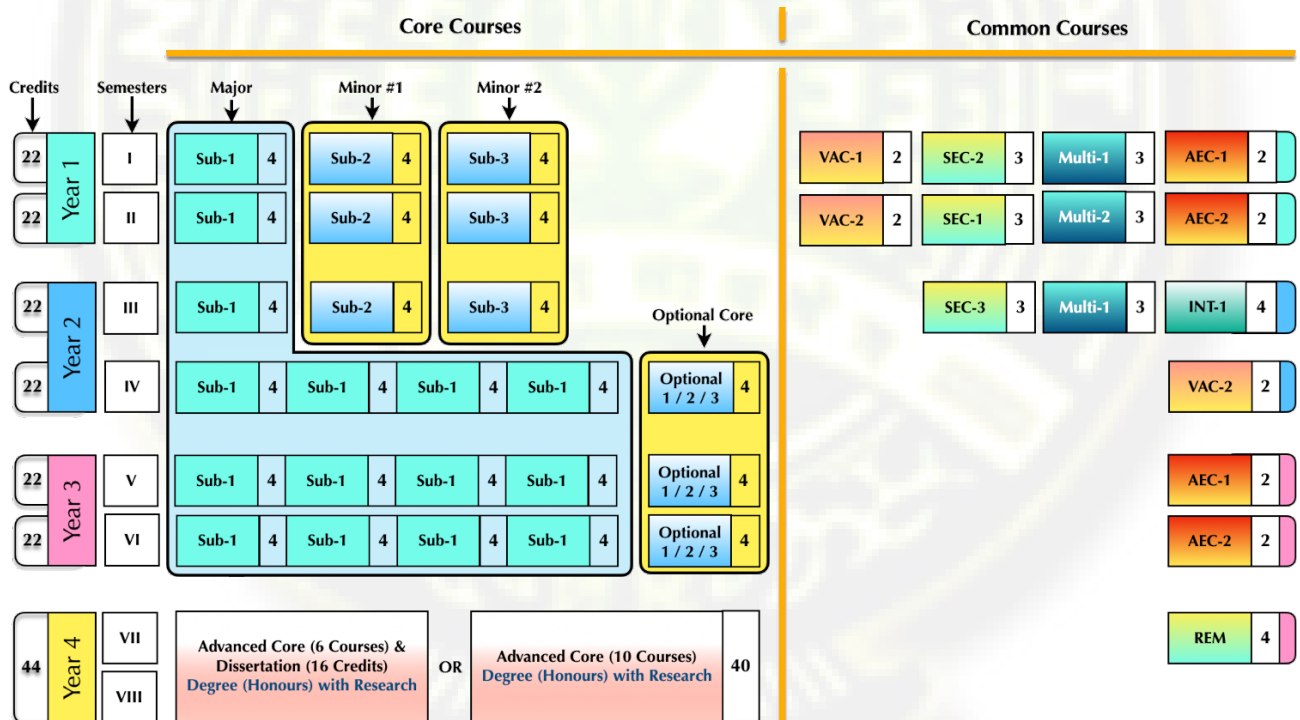

Figure 3.1: Core Courses options — Option for a Major and two Minors.

#### 3.1.1 Legends

VAC – Value Added Course  
 SEC – Skill Enhancement Course  
 Multi – Multidisciplinary Course

AEC – Ability Enhancement Course  
 INT – Internship  
 REM – Research Methodology



### 3.1.2 Core Course description

In this case, a student takes a Major subject with minimum 15 courses and two Minor subjects with a minimum of 3 courses each over a period of three years. Apart from these, the student also needs to take 3 Core courses during Semesters 4-6 where s/he can pick any of the three core subjects s/he has already studied.

## 3.2 | Degree with only Minors

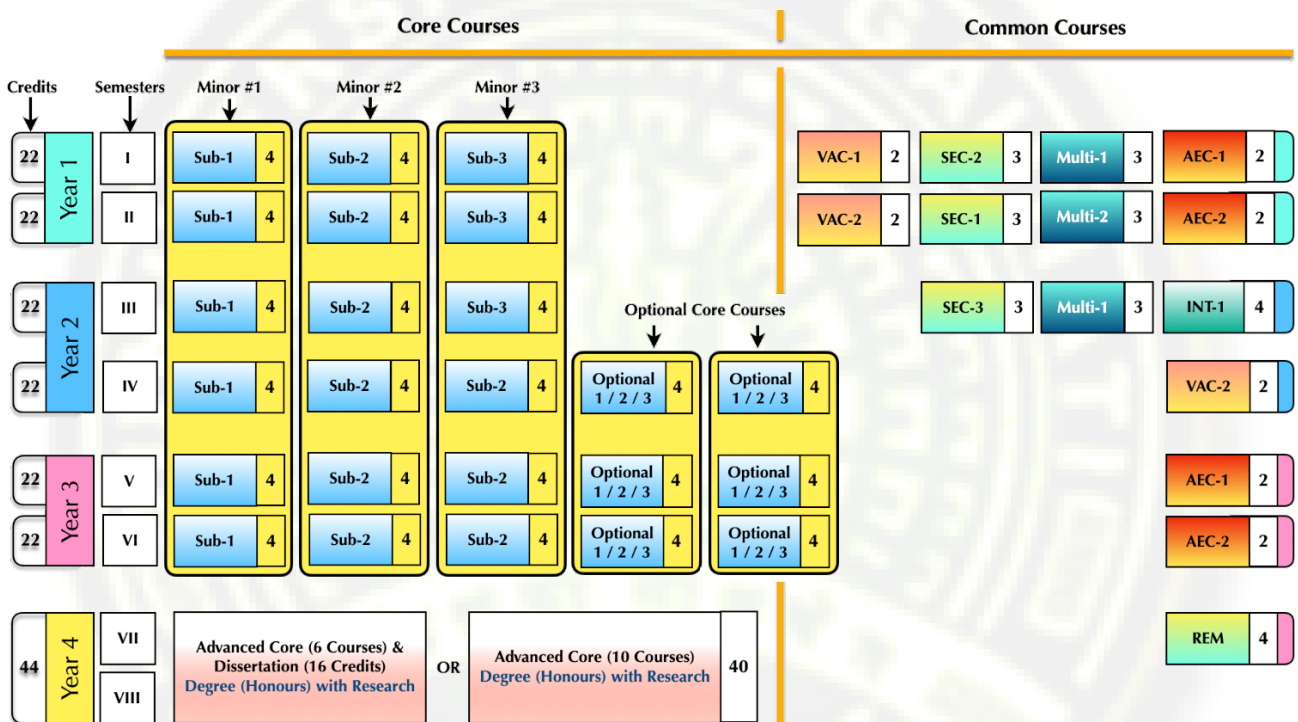

Figure 3.2: Core Courses options — Option with only Minors.

### 3.2.1 Core Course description

In this case, a student takes a three Minor subjects each with a minimum 6 courses over a period of three years. Apart from these, the student also needs to take 6 Core courses during Semesters 4-6 where s/he can pick any of the three core subjects s/he has already studied.

# 4 | Examples

In this examples, we are providing two options a student can have. All the examples given below are for a 3-year degree programme. The fourth year can simply be added to the examples.

## 4.1 | Example #1 – Degree with Major and Minors

In this example, we show the subject distribution for a Bachelor Degree in Arts with Major and two Minors. As one can see, there are 12 **Open Core Credits** to be earned by a student above the minimum requirement of 120 credits. These open core can be utilised for any of the following:

- For another Minor
- For one of the Minor so that it can be converted to a Double Major
- To complete course from the fourth year

In the figure below (Fig.4.1), the distribution is shown visually. The papers marked in **bold-red** denote that they are compulsory. One should note that the Internship can be done in any semester within the 3rd and the 6th. As an internship is always done during a break, it essentially *does not* interfere with the semester classes.

Semester	Core #1	Courses	Credits	Core #2	Courses	Credits	Core #2	Courses	Credits	Open Core Credits	Common Credits	Total Credits
I	History	<b>1</b>	4	Pol Sc	<b>1</b>	4	Economics	<b>1</b>	4		10	22
II	History	<b>1</b>	4	Pol Sc	<b>1</b>	4	Economics	<b>1</b>	4		10	22
III	History	<b>1</b>	4	Pol Sc	<b>1</b>	4	Economics	<b>1</b>	4		10	22
IV	History	<b>1+3</b>	16							4	2	22
V	History	<b>1+3</b>	16							4	2	22
VI	History	<b>1+3</b>	16							4	2	22
	<b>History</b>	<b>15</b>	<b>60</b>	<b>Pol Sc</b>	<b>3</b>	<b>12</b>	<b>Economics</b>	<b>3</b>	<b>12</b>	<b>12</b>	<b>36</b>	<b>132</b>
	Major			Minor #1			Minor #2					

Figure 4.1: Example #1 – Degree with a Major and two Minors.

## 4.2 | Example #2 – Degree without Major

In this example (Fig.4.2), we show the subject distribution for a Bachelor Degree in Arts without Major. The **OPen Core Credits** can be utilised as described in case of Example #1.

Semester	Core #1	Courses	Credits	Core #2	Courses	Credits	Core #2	Courses	Credits	Open Core Credits	Common Credits	Total Credits
I	History	1	4	Pol Sc	1	4	Economics	1	4		10	22
II	History	1	4	Pol Sc	1	4	Economics	1	4		10	22
III	History	1	4	Pol Sc	1	4	Economics	1	4		10	22
IV	History	1+1	8	Pol Sc	1	4	Economics	1	4	4	2	22
V	History	1+1	8	Pol Sc	1	4	Economics	1	4	4	2	22
VI	History	1+1	8	Pol Sc	1	4	Economics	1	4	4	2	22
	History	9	36	Pol Sc	6	24	Economics	6	24	12	36	132
	Minor #1			Minor #2			Minor #3					

Figure 4.2: Example #2 – Degree with no Major.



## 5 | Subject Details – Core Subjects

In this Chapter, we describe all the existing subject details, their dependencies, and prerequisites. All the subjects are broadly divided into four streams. They are:

1. Arts
2. Science
3. Commerce & Management
4. Interdisciplinary

All these streams have their own subject groups. For example, **Physical Science** is a subject group of Science stream. Or, **Other Language** is a subject group of Arts stream. These groups with their parent streams are shown in Fig.5.1

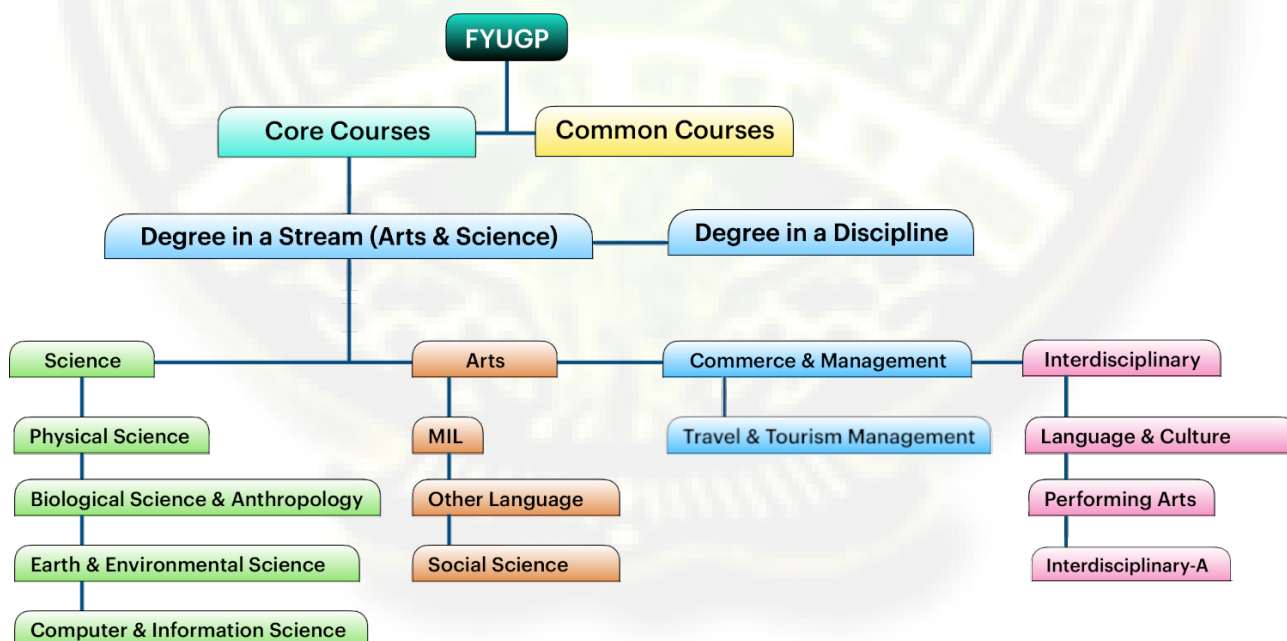

Figure 5.1: Streams and their subject groups.

All the subject groups will have a bunch of individual subjects belonging to the respective groups, which will be described in the next section. The following applies to all these groups except the group for Commerce & Management, which will be described separately.

- All groups have their own conditions and prerequisites.
- A student can combine any three subjects from these groups subject to the fulfilment of the requirements and prerequisites.

Gauhati University will release a *digital utility* in due course of time through which a student will be able to see what subjects can be studied under the FYUGP in GU (based on their Class XII-level subjects and preferences).

## 5.1 | Subject groups

The three streams (as shown in the previous page) — (a) Arts, (b) Science, and (c) Interdisciplinary — has their own subject groups. Each of these groups has their own constraints as to up to how many number of subjects from each subject-group can be chosen by a student. This is indicated in the previous figure with the word **Max**.

### 5.1.1 Key points

- A student can choose any three subjects from the subject groups Arts, Science, and Interdisciplinary.
- However, the ability to take a subject from a particular group will depend on prerequisites (qualifications that a student must have, see the subsection below on Prerequisites & Requirements) and Group Constraints (see below).
- All subjects have at least one paper compulsory in all semesters.

#### Note

*The subjects in the Stream – Commerce & Management – will be described separately.*

## 5.2 | Prerequisites, Requirements, & Constraints

The **prerequisites** are subjects that a student *must* have studied (and passed) in an earlier level of education (usually Class XI & XII) in order to be able to choose a subject. Essentially, all the levels of a subject have their prerequisites, which are spelled out very visibly in the cover page of a course syllabus.

In contrast to the prerequisites, **requirements** are certain conditions attached to some core subjects. For example, if a student wants to study Botany as a core subject, Chemistry as another core subjects has to be chosen. This is a 'requirement'. However, if one chooses Chemistry, there is no requirements.

Constraints refer to the maximum number of subjects a student can choose from a particular subject-group. For example, one can choose a maximum of any two subjects from the group – **Biological Science & Anthropology**. This is a 'constraints' for this group.

Please read further to know the stream-wise subjects with group-constraints.

### 5.3 | Subject Group — Arts

- This stream has three Subject Groups – (1) MIL (Modern Indian Languages), (2) Other Language, and (3) Social Science.
- The maximum number of subjects which can be chosen from each group is shown in the Fig.5.3.
- All together this stream has 17 (seventeen) subjects.

**Note**

*The subjects shown yellow colour MAY NOT have a Major option, at present. Please check with your college to know if a Major in these subjects are allowed.*

Arts			Interdisciplinary		
MIL	Other Language	Social Sciences	Language & Culture	Performing Arts	Interdisciplinary-A
Assamese	Arabic	Economics <sup>†</sup>	Folklore	Sattriya Tradition	Journalism & Mass Communication
Bengali	English	Education	Linguistics		Library & Information Science
Bodo	Persian	History			Community Science (Home Science)
Hindi		Philosophy			Human Rights Education
Manipuri		Political Science			
Nepali		Psychology			
Sanskrit		Sociology			
			Commerce & Management		
			Travel & Tourism Management		
Max 1	Max 1	Max 3	Max 1	Max 1	Max 1

<sup>†</sup> Dual-Stream subjects

Figure 5.2: Stream-wise Subject Groups for Arts and Interdisciplinary.

### 5.4 | Subject Group — Interdisciplinary<sup>†</sup>

- This stream has three Subject Groups – (1) Language & Culture, (2) Performing Arts, and (3) Interdisciplinary-A (Group A).
- The maximum number of subjects which can be chosen from each group is shown in the Fig.5.3.
- All together this stream has 5 (five) subjects.
- None of the subjects in this stream has Major option.

<sup>†</sup> The subject **Home Science** is being renamed as **Community Science**. Approval pending.

## 5.5 | Subject Group — Science

- This stream has four Subject Groups – (1) Physical Science, (2) Biological Science & Anthropology, (3) Earth & Environmental Science, and (4) Computer & Information Science.

Science			
Physical Science	Biological Science & Anthropology	Earth & Environmental Science	Computer & Information Science
Physics / Electronics Science	Anthropology <sup>†</sup>	Environmental Science	Computer Science
Chemistry	Botany	Geology	Computer Application
Mathematics <sup>†</sup>	Zoology	Geography <sup>†</sup>	
Statistics	Biotechnology		
Instrumentation	Microbiology		
<sup>†</sup> Dual-Stream subjects			
Max 3	Max 2	Max 1	Max 1

Figure 5.3: Stream-wise Subject Groups for Science.

- The maximum number of subjects which can be chosen from each group is shown in the Fig.5.3.
- The subjects included in one box with a '/' sign indicates that a student can choose either of the two subjects.
- All together this stream has 17 (seventeen) subjects.
- The subjects – Biotechnology, Microbiology, Environmental Science, Computer Application, and Information Technology do not have Major option.

## 5.6 | Major subjects

At present, the following subjects have Major as well as Minor options. These subjects are

- **Arts Stream**
  - **MIL**  
Assamese, Bengali, Bodo, Hindi, Manipuri, Nepali, and Sanskrit
  - **Other Language**  
Arabic, English, and Persian
  - **Social Science**  
Economics, Education, History, Philosophy, Political Science, Psychology, and Sociology



- **Science**

- **Physical Science**  
Chemistry, Electronics Science, Instrumentation, Mathematics, Physics, and Statistics
- **Biological Science & Anthropology**  
Anthropology, Botany, and Zoology
- **Earth & Environmental Science**  
Geology, Geograpy
- **Computer & Information Science**  
Computer Science

## 5.7 | Minor Subjects

In addition to all the subjects mentioned under the Major-Category, a student can also have Minors in the following subjects.

- **Interdisciplinary**

- **Language & Culture**  
Folklore, Linguistics
- **Performing Arts**  
Sattriya Tradition
- **Interdisciplinary-A**  
Journalism & Mass Communication, Community Science (Home Science), and Human Rights Education

**Important**

*The subjects ONLY have Minor options, at present. However, the prospective student should check with respective college to see if a Major is being offered.*

- **Science**

- **Biological Science & Anthropology**  
Biotechnology, Microbiology
- **Earth & Environmental Science**  
Environmental Science
- **Computer & Information Science**  
Computer Application



## 6 | Multidisciplinary & Skill Courses

### 6.1 | Multidisciplinary subjects

As mentioned before, the multidisciplinary subjects are Class XII-standard subjects. In GU-FYUGP, the entire multidisciplinary group is divided into six categories. All these categories will have three papers each, to be studied during Semesters 1-3. Below, we list these categories and their broad contents.

1. **Natural & Physical Science**  
Physics & Astronomy, Chemistry, Biological Science, and Earth Science.
2. **Mathematical Science**  
Basic Mathematics and Statistics
3. **Computer Application**  
Introductory Computer Applications and Programming, Information Technology
4. **Information & Media**  
Basic Information and Media, Mass Media and Communication
5. **Commerce & Management**  
Basic Business Management, Introductory Commerce
6. **Humanities & Social Science**  
Basic Economics, Political Science, History, Philosophy, and Psychology, Women's and Gender Studies

### 6.2 | Skill Courses

A student can take any skill course offered by the respective institution during Semesters 1-3.



## 7 | List of prerequisites & requirements

Here, we list all the prerequisites and requirements for the Core Subjects.

### 7.1 | Arts

Following are the prerequisites for all subjects (39 of them) of Arts, Science, Interdisciplinary streams and one subject under Commerce & Management at the entry level of the FYUGP i.e. at the first semester.

Stream : Arts		
MIL		
Subject	Prerequisites	Requirements
Assamese	Assamese (X-level) for Minor & (XII-level) for Major	None
Bengali	Assamese / Bengali (X-level)	
Bodo	Bodo (XII-level)	
Hindi	Hindi (X-level)	
Manipuri	Manipuri (XII-level) for Major & (X-Level) for Minor	
Nepali	None	
Sanskrit	Sanskrit (X-level)	

Stream : Arts		
Other Language		
Subject	Prerequisites	Requirements
Arabic	None	None
English	English (X-Level)	
Persian	None	

Figure 7.1: Prerequisites & Requirements for Arts subjects (MIL & Other Language).

Stream : Arts		
Social Science		
Subject	Prerequisites	Requirements
Economics	None	None
Education		
History		
Philosophy		
Political Science		
Psychology		
Sociology		

Figure 7.2: Prerequisites & Requirements for Arts subjects (Social Science).

## 7.2 | Interdisciplinary

Stream : Interdisciplinary		
Language & Culture		
Subject	Prerequisites	Requirements
Folklore	None	None
Linguistics		

Stream : Interdisciplinary		
Performing Arts		
Subject	Prerequisites	Requirements
Sattriya Tradition	None	None

Stream : Interdisciplinary		
Interdisciplinary-A		
Subject	Prerequisites	Requirements
Journalism & Mass Communication	None	None
Library & Information Science		
Home Science		
Human Rights Education		

Figure 7.3: Prerequisites & Requirements for Interdisciplinary subjects.

### 7.3 | Science

Stream : Science		
Physical Science		
Subject	Prerequisites	Requirements
Chemistry	Chemistry AND Math (XII-Level) for Major and only Chemistry (XII-Level) for Minor	None
Electronics Science	Physics AND Math (XII-Level)	None
Instrumentation	Physics AND Math (XII-Level)	Physics AND Math
Mathematics	Math (XII-level)	None
Physics	Physics AND Math (XII-Level)	Math
Statistics	Math (XII-level)	None

**Either / Or**

Stream : Science		
Biological Science & Anthropology		
Subject	Prerequisites	Requirements
Anthropology	None	None
Botany	Biology (XII-Level)	Chemistry
Biotechnology	Biology AND Chemistry (XII-Level)	Chemistry
Microbiology	Biology AND Chemistry (XII-Level)	Chemistry
Zoology	Biology AND Chemistry (XII-Level)	Chemistry

Stream : Science		
Earth & Environmental Science		
Subject	Prerequisites	Requirements
Environmental Science	Science (XII-Level)	Chemistry
Geology	Science (XII-Level)	None
Geography	None	None

Stream : Science		
Computer & Information Science		
Subject	Prerequisites	Requirements
Computer Science	Science AND Math (XII-Level)	None
Computer Application	None	None

Figure 7.4: Prerequisites & Requirements for Science subjects.

## 7.4 | Commerce & Management

Stream : Commerce & Management		
Subject	Prerequisites	Requirements
Travel & Tourism Management	None	None

Figure 7.5: Prerequisites & Requirements one subject under Commerce & Management.



## 8 | Bachelor's Degree in Commerce

The Bachelor's Degree in Commerce is a standalone course with the FYUGP structure. However, with this degree, one can have choice of Majors in (i) Accountancy, (ii) Finance, (iii) Human Resource Management, and (iv) Marketing Management. The Common Courses are same for all. Below, we show the Major options as well as the Common Courses for a Bachelor's Degree in Commerce.

### 8.1 | Common Courses

Credits	Semester	Common Courses				
10	I	<b>Multidisciplinary 1</b>	<b>VAC 1</b>	<b>AEC 1</b>	<b>Skill 1</b>	
		Business Mathematics	Environmental Science	English Communication	IT in Business	
10	II	<b>Multidisciplinary 2</b>	<b>VAC 2</b>	<b>AEC 2</b>	<b>Skill 2</b>	
		Business Economics	Trade & Commerce in India	Business Communication	E-Commerce	
10	III	<b>Multidisciplinary 3</b>			<b>Skill 3</b>	<b>Internship</b>
		Business Statistics			New Venture Planing	On a chosen topic
2	IV		<b>VAC 3</b>			
			Business Etiquette			
2	V			<b>AEC 3</b>		
				Soft Skill		
2	VI			<b>AEC 4</b>		
				E-Filling of Returns		
4	VII	<b>Research Methodology</b>				
		1 Course (4 Credits)				
0	VIII					

Figure 8.1: Bachelor's Degree in Commerce – Common Courses.

## 8.2 | Major : Accountancy

Major : Accountancy						
Credits	Semester	Core Courses (Credit per Course : 4)				
12	I	<b>Core 1</b>	<b>Core 2</b>	<b>Core 3</b>		
		Business Organisation & Management	Financial Accounting	Indian Financial System		
12	II	<b>Core 4</b>	<b>Core 5</b>	<b>Core 6</b>		
		Corporate Accounting	Principles & Practice of Management	Principles of Marketing		
12	III	<b>Major 1</b>	<b>Major 2</b>	<b>Major 3</b>		
		Advance Financial Accounting	Entrepreneurship	Business Laws		
20	IV	<b>Major 4</b>	<b>Major 5</b>	<b>Major 6</b>	<b>Major 7</b>	<b>Minor 1</b>
		Fundamentals of Financial Management	Cost Accounting	Income Tax Laws & Practices	Advanced Corporate Accounting	Financial Market Operations
20	V	<b>Major 8</b>	<b>Major 9</b>	<b>Major 10</b>	<b>Major 11</b>	<b>Minor 2</b>
		Indian Economy	Management Accounting	Fundamentals of Investment	Indirect Taxes	Corporate Laws
20	VI	<b>Major 12</b>	<b>Major 13</b>	<b>Major 14</b>	<b>Major 15</b>	<b>Minor 3</b>
		International Business	Operations Research in Business	Computerised Accounting	Auditing & Assurance	Project Management
16	VII	<b>Advanced Core</b>				<b>Advanced Core</b>
		4 Course (16 Credits)				4 Course (16 Credits)
20	VIII	<b>Advanced Core</b>	<b>Dissertation</b>			<b>Advanced Core</b>
		1 Course (4 Credits)	1 Course (16 Credits)			5 Course (20 Credits)

← Degree (Honours)      Degree (Honours) with Research →

Figure 8.2: Bachelor's Degree in Commerce – Accountancy Major.

### 8.3 | Major : Finance

Major : Finance						
Credits	Semester	Core Courses (Credit per Course : 4)				
12	I	<b>Core 1</b>	<b>Core 2</b>	<b>Core 3</b>		
		Business Organisation & Management	Financial Accounting	Indian Financial System		
12	II	<b>Core 4</b>	<b>Core 5</b>	<b>Core 6</b>		
		Corporate Accounting	Principles & Practice of Management	Principles of Marketing		
12	III	<b>Major 1</b>	<b>Major 2</b>	<b>Major 3</b>		
		Banking	Entrepreneurship	Business Laws		
20	IV	<b>Major 4</b>	<b>Major 5</b>	<b>Major 6</b>	<b>Major 7</b>	<b>Minor 1</b>
		Fundamentals of Financial Management	Financial Market Operations	Insurance	Cost & Management Accounting	Direct & Indirect Taxes
20	V	<b>Major 8</b>	<b>Major 9</b>	<b>Major 10</b>	<b>Major 11</b>	<b>Minor 2</b>
		Indian Economy	Micro Finance	Financial Services	Fundamentals of Investment	Corporate Laws
20	VI	<b>Major 12</b>	<b>Major 13</b>	<b>Major 14</b>	<b>Major 15</b>	<b>Minor 3</b>
		International Business	Operations Research in Business	Treasury & Risk Management	Marketing of Services	Project Management
16	VII	<b>Advanced Core</b>				<b>Advanced Core</b>
		4 Course (16 Credits)				4 Course (16 Credits)
20	VIII	<b>Advanced Core</b>	<b>Dissertation</b>			<b>Advanced Core</b>
		1 Course (4 Credits)	1 Course (16 Credits)			5 Course (20 Credits)

← Degree (Honours)      Degree (Honours) with Research →

Figure 8.3: Bachelor's Degree in Commerce – Finance Major.

## 8.4 | Major : Human Resource Management

Major : Human Resource Management						
Credits	Semester	Core Courses (Credit per Course : 4)				
12	I	<b>Core 1</b>	<b>Core 2</b>	<b>Core 3</b>		
		Business Organisation & Management	Financial Accounting	Indian Financial System		
12	II	<b>Core 4</b>	<b>Core 5</b>	<b>Core 6</b>		
		Corporate Accounting	Principles & Practice of Management	Principles of Marketing		
12	III	<b>Major 1</b>	<b>Major 2</b>	<b>Major 3</b>		
		Human Resource Management	Entrepreneurship	Business Laws		
20	IV	<b>Major 4</b>	<b>Major 5</b>	<b>Major 6</b>	<b>Major 7</b>	<b>Minor 1</b>
		Fundamentals of Financial Management	Labour Laws	Industrial Relations	Cost & Management Accounting	Direct & Indirect Taxes
20	V	<b>Major 8</b>	<b>Major 9</b>	<b>Major 10</b>	<b>Major 11</b>	<b>Minor 2</b>
		Indian Economy	Strategic Human Resource Management	Labour Welfare & Social Security	Performance Management	Corporate Laws
20	VI	<b>Major 12</b>	<b>Major 13</b>	<b>Major 14</b>	<b>Major 15</b>	<b>Minor 3</b>
		International Business	Operations Research in Business	Technology & Human Resource Management	Training & Development	Project Management
16	VII	<b>Advanced Core</b>				<b>Advanced Core</b>
		4 Course (16 Credits)				4 Course (16 Credits)
20	VIII	<b>Advanced Core</b>	<b>Dissertation</b>			<b>Advanced Core</b>
		1 Course (4 Credits)	1 Course (16 Credits)			5 Course (20 Credits)

← Degree (Honours)      Degree (Honours) →  
 with Research

Figure 8.4: Bachelor's Degree in Commerce – Human Resource Management Major.

## 8.5 | Major : Marketing Management

Major : Marketing Management						
Credits	Semester	Core Courses (Credit per Course : 4)				
12	I	<b>Core 1</b>	<b>Core 2</b>	<b>Core 3</b>		
		Business Organisation & Management	Financial Accounting	Indian Financial System		
12	II	<b>Core 4</b>	<b>Core 5</b>	<b>Core 6</b>		
		Corporate Accounting	Principles & Practice of Management	Principles of Marketing		
12	III	<b>Major 1</b>	<b>Major 2</b>	<b>Major 3</b>		
		Advertising	Entrepreneurship	Business Laws		
20	IV	<b>Major 4</b>	<b>Major 5</b>	<b>Major 6</b>	<b>Major 7</b>	<b>Minor 1</b>
		Fundamentals of Financial Management	Retail Management	Customer Relationship Management	Cost & Management Accounting	Direct & Indirect Taxes
20	V	<b>Major 8</b>	<b>Major 9</b>	<b>Major 10</b>	<b>Major 11</b>	<b>Minor 2</b>
		Indian Economy	Consumer Behaviour	Personal Selling & Salesmanship	Brand Management	Corporate Laws
20	VI	<b>Major 12</b>	<b>Major 13</b>	<b>Major 14</b>	<b>Major 15</b>	<b>Minor 3</b>
		International Business	Operations Research in Business	Consumer Affairs & Customer Care	Marketing of Service	Project Management
16	VII	<b>Advanced Core</b>				<b>Advanced Core</b>
		4 Course (16 Credits)				4 Course (16 Credits)
20	VIII	<b>Advanced Core</b>	<b>Dissertation</b>			<b>Advanced Core</b>
		1 Course (4 Credits)	1 Course (16 Credits)			5 Course (20 Credits)

← Degree (Honours)
Degree (Honours) → with Research

Figure 8.5: Bachelor's Degree in Commerce – Marketing Management Major.



# 9 | Degree in a Discipline

The GU-FYUGP has quite a couple of subjects, where we offer 'Degree in a Discipline'. These also include all vocational courses.

## 9.1 | Salient features

- Has the same FYUGP structure – i.e. Core Courses with a minimum of 84 credits and Common Courses credits of 36 (in a 3-year programme).
- No Majors or Minors.
- Students study certain pre-defined courses designed for the respective discipline.

## 9.2 | List of disciplines & degrees

1. Computer Application  
*Bachelor's in Computer Application*
2. Biotechnology  
*Bachelor's of Science in Biotechnology*
3. Business Administration  
*Bachelor's of Business Administration*
4. Information Technology  
*Bachelor's of Science in IT*
5. Microbiology  
*Bachelor's of Science in Microbiology*
6. Applied Science  
*Bachelor's of Science in Applied Science*

### 9.2.1 Vocational Disciplines

1. Acting (Entertainment)
2. Animation & Graphic Design

#### **Vocational Subjects**

*These subjects are Vocational Subjects, where the degree awarded is Bachelor's Degree in Discipline (Vocation).*

3. Banking And Financial Services
  4. Catering Technology & Hotel Management
  5. Fashion Technology
  6. Food Processing & Quality Management
  7. Food Processing (Agriculture)
  8. Food Processing Technology
  9. Herbal Processing Technology
  10. Information Technology
  11. Mass Communication & Journalism
  12. Mass Media
  13. Medical Lab & Molecular Diagnostic Technology
  14. Medical Laboratory Technician
  15. Physical Education
  16. Retail Management
  17. Retail Management & Information Technology
  18. Small Tea Garden Management
  19. Theatre & Stage Craft
  20. Tourism & Hospitality Management
  21. Tourism & Service Industry
  22. Tourism & Travel Management
-